

# Automatic Master Ice Balers

Over  
300 machines in  
operation!

## Optional FuseAire 4 Heat Sealer



- Provides perfect closing system
- Low maintenance
- Uses no consumables
- Safe and easy to use



JMC IB-1008 WITH OPTIONAL JMC SPACE  
SAVER CONVEYOR AND BYPASS SYSTEM

Automatic Master Baling of various types and sizes of pre-packaged ice products. Accommodates product bags with a common width and adjustable length, from all types of manual and automated packaging lines. Consider the optional JMC FuseAire 4 Heat Sealer for a reliable and trouble free Automatic Master Baling system.

### FEATURES and BENEFITS

- Saves on manual labour
- Increases production
- Fully automatic
- Fast bag changeover
- Customized to suit applications
- Uniform Master bags for easier palletizing (saves warehouse space)
- Proven technology and reliable performance
- User friendly
- All adjustments can be done from the touch screen

2 year limited warranty on JMC parts.

Call for more information 1-800-263-5252.

[www.jmcpackaging.com](http://www.jmcpackaging.com)

At JMC Innovation Never Stops



SINCE 1961

### MODELS

IB 1007  
IB 1008  
IB 1009  
IB 1010

# Automatic Master Ice Balers

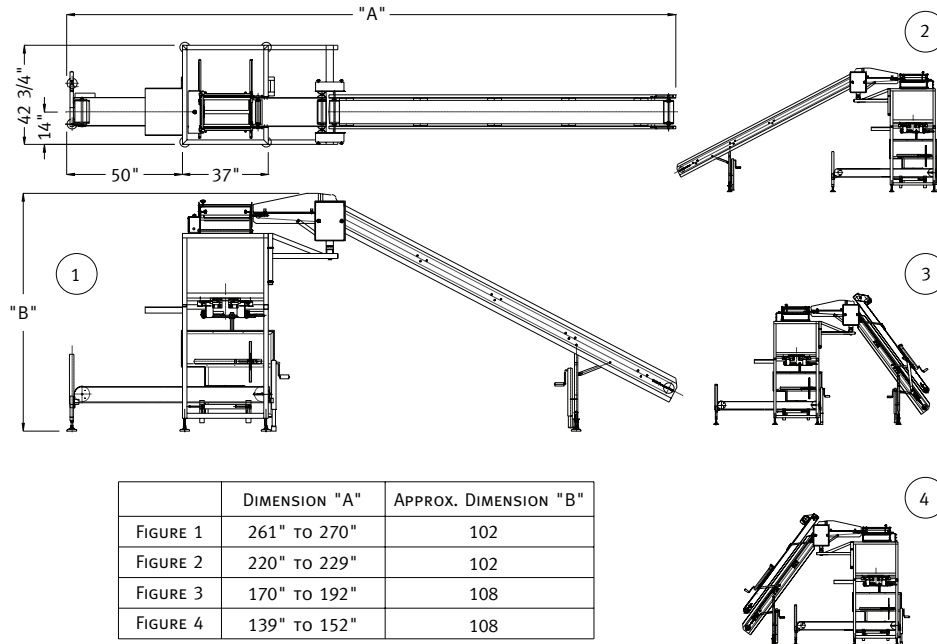

**JMC AUTOMATIC BALING SYSTEM:** Counts and accumulates pre-packaged ice to be discharged into a Master Poly Bag and then automatically presents the upright bag on a conveyor into a closing system.

## STANDARD FEATURES:

- OMRON P.L.C. (programmable logic controller)
- 4 standard fixed width magazine sides - choose between 7" to 10" model type
- Bag inflation system
- Incline and accelerator conveyor
- Infeed mechanism
- Bale pusher with bag transport grippers
- Take away conveyor
- Fully approved electrical control panel with interlock
- Swingaway control panel
- Stainless steel panels and product contact surfaces
- Epoxy powder baked finish
- Leveling feet
- "incline" or "reversed" configuration available
- Compact Frame available (consult factory for dimensions)

## OPTIONAL FEATURES:

- JMC Space Saver Incline Conveyor (Figure 3 or Figure 4)
- JMC FuseAire 4 Hot Air Sealer (trimmer available)
- JMC Bale Kicker
- Spare Parts Kit
- Mobility Kit
- Stainless Steel frame, conveyor and components
- Bypass system with conveyor and chute
- Bag Sense "no bag-no dump"

## SPECIFICATIONS:

Power requirements: 230/460/550 volt 3 ph.60 hz  
(208 volts minimum)  
Air requirements: 5 CFM @ 80 PSI  
Capacity: Up to 10 Master bags per minute  
(see your representative)  
Shipping Weight: Approx. 2500 lbs. (standard)

*Manufactured for the world market by:*

## JMC PACKAGING EQUIPMENT

3470 Mainway  
Burlington, Ontario, Canada L7M 1A8  
Toll-free: 1-800-263-5252  
If busy, call: (905) 335-4196  
FAX: (905) 335-4201  
E-Mail: [jmc@nas.net](mailto:jmc@nas.net)  
Internet: [www.jmcpackaging.com](http://www.jmcpackaging.com)



**"ORDER BY 4:00 AND OUT THE DOOR!"**  
5709 Harrison Ave. • Cincinnati, OH 45248  
1.800.543.1581 • [modernice.com](http://modernice.com)